

MANUAL INSTRUCTION FOR HANDBIKE ATTACHMENT

 MODEL: MT03 & MT04

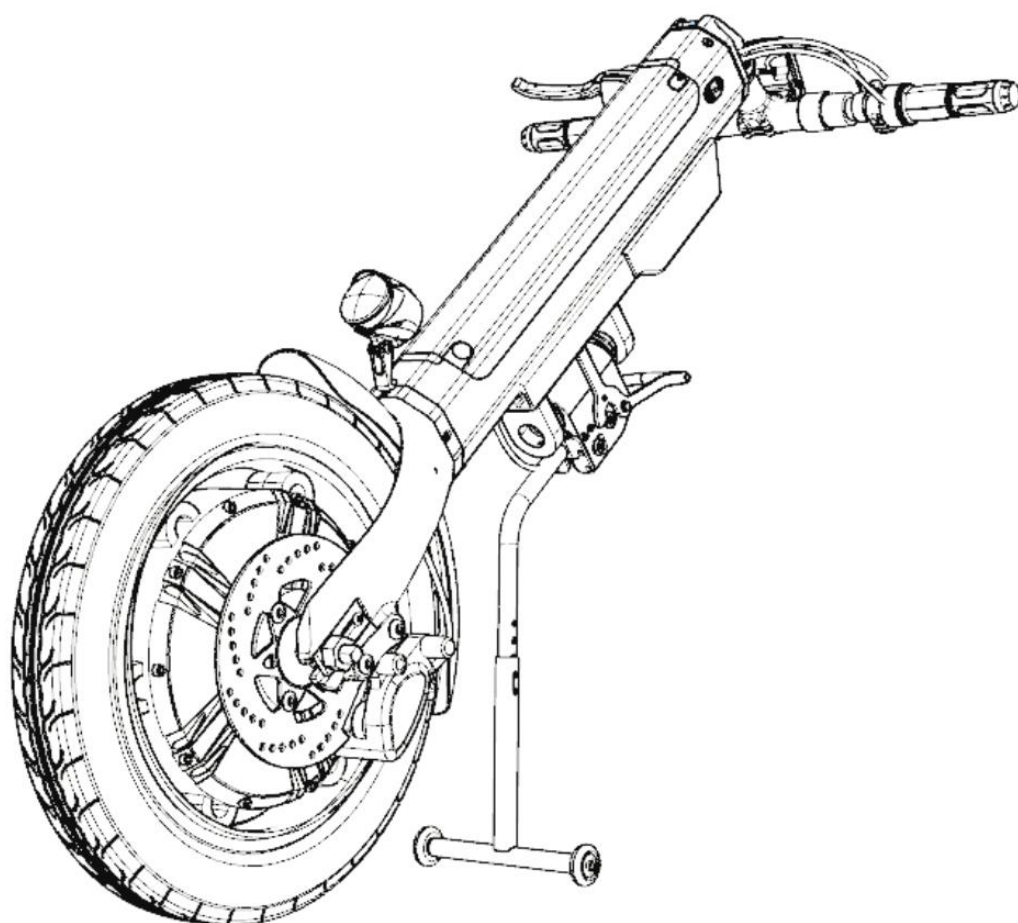

User: Before using the handbike, please read this manual instruction carefully and save it for reference.

Contents

Product description	3
Announcements.....	3
Product structure	4
Instruction for instrument switches etc.....	5
Technical Parameters and Indicators	6
Unpacking Installation Instructions.....	7
MT03 Manual Instruction	9
MT03 Connection structure match with manual wheelchair.....	9
MT03 First time connect with manual wheelchair instruction.....	10-11
MT03 Disconnecting with wheelchair instruction	13
MT04 Manual Instruction	14
MT04 Connection structure diagram.....	14
MT04 Clamp installation position.....	14
MT04 First time connecting with wheelchair instruction.....	15-15
MT04 Disconnecting with wheelchair instruction	17
Battery Instructions	18
Battery related instructions	18
Battery Usage	18
Notes for charging	19-19
Battery Installation and removal	21
Battery Charging.....	23
Over Discharge Protection Device.....	23
Over current protect device	23
Warranty Coverage	24
Not covered by warranty	25
Labels, Packing Logo Design	26
Accessories	27

Product description

Announcements

【Scope with application】

It is used to help disabled and elderly person with mobility difficulties to move within a certain distance(used with a manual wheelchair).

【Intended usage environment】

The handbike is used for outdoor and indoor, such as hospital, nursing home etc.

Temperature: $5\pm 2^{\circ}\text{C}\sim 40\pm 2^{\circ}\text{C}$;

Atmospheric pressure: $860\pm 2\%\text{hPa}\sim 1060\pm 2\%\text{hPa}$;

Humidity: $10\pm 3\%\sim 80\pm 3\%$

Power condition:

Charging voltage: $\text{AC } 100\pm 2\%\text{V}\sim 240\pm 2\%\text{V}, 50\pm 1\%\text{Hz}$;

Battery voltage: $\text{DC } 48\pm 2\%\text{V}$;

Motor power: $\geq 800\text{W}$;

 Driving conditions: Do not make sharp turns when driving at high speed.

【For people】

The disabled and the elderly and infirm with mobility difficulties.

【Initial Install】

Must be approved by our company and installed by professional and technical staffs.

Product structure

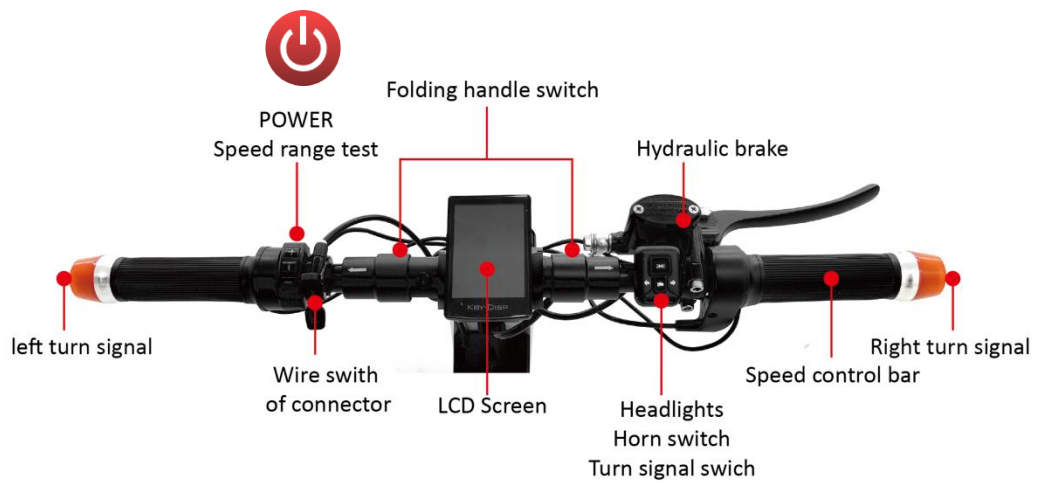

Instruction for instrument switches etc.



Technical Parameters and Indicators

【Product main parameters】

Size and weight	
Expanded size (length x width x height)	1050*650*860mm (Stance)
Packing size (length x width x height)	1170*520*310mm
Weight capacity	120kg
Self-weight	21kg(17kg Without battery)
Motor	
Type	Brushless DC motor
Rated power	≥800 W
Input voltage	DC ≥48V
Number	1 PC
Brake system	Hydraulic brake
Battery	
Type	Lithium-ion Battery
Nominal capacity	12Ah
The output voltage	DC ≥48V
Number	1(If not used for 2 weeks, charge once)
Controller	
Type/plug type	Brushless DC sine wave controller
Output voltage/current	DC ≥48V
Charger	
Type	Take away portable
Input voltage	AC: 100V~240V(±2%V),50Hz(±1%Hz)
The output voltage	≥48V
Tires	
Outer diameter x tire width	16 Inch *2.125 Inch
Type	Pneumatic tire
Material	Rubber
Number	1 PC
Performance	
Maximum speed	≤30km/h
Horizontal road braking performance	≤3m
Maximum safe slope performance	≤3m (10°)
Climbing ability	≤12°
Theoretical driving distance	50-60km

Unpacking Installation Instructions

【Installation Preparation】

Foot support installation:as shown in the picture, install the foot support on the frame with an inner hexagon (tool: 5mm inner hexagon wrench).

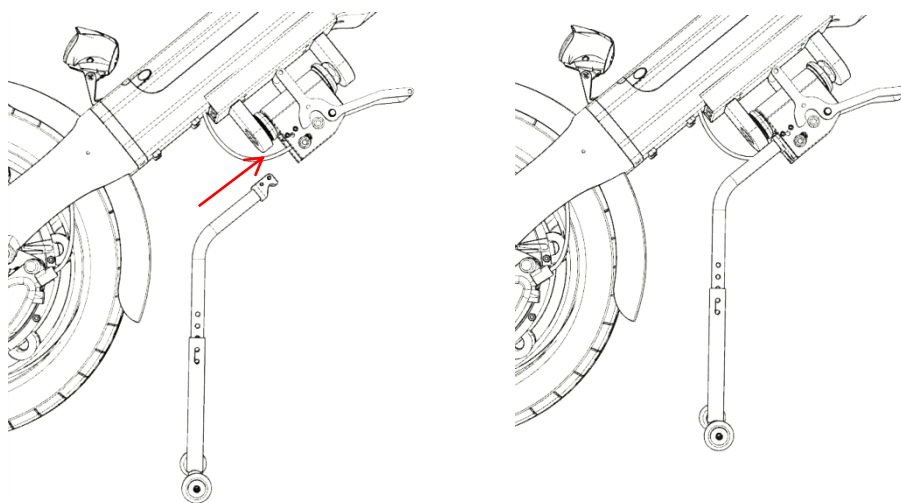

【Install the display】

Put the monitor in the middle of the handle,tighten the screws using a wrench.(tool:2.5mm inner hexagon wrench).



【Foldable handlebar Installation】

1. As shown the picture, adjust handlebar height according to individual situation ,rotate the handlebar to a suitable height, then fix bolts at the prop.(Tool: 5mm inner hexagon wrench).

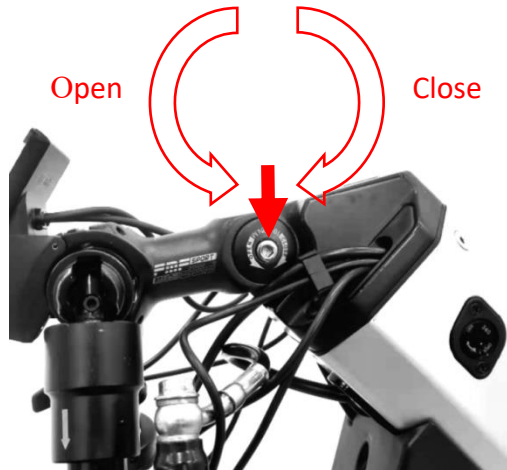

【Unfolding the foldable handlebar】

1. Rotate the left and right handlebars to the outside directions by 90°, when the slider is automatically returned to the position, unfolding the handlebar is completed

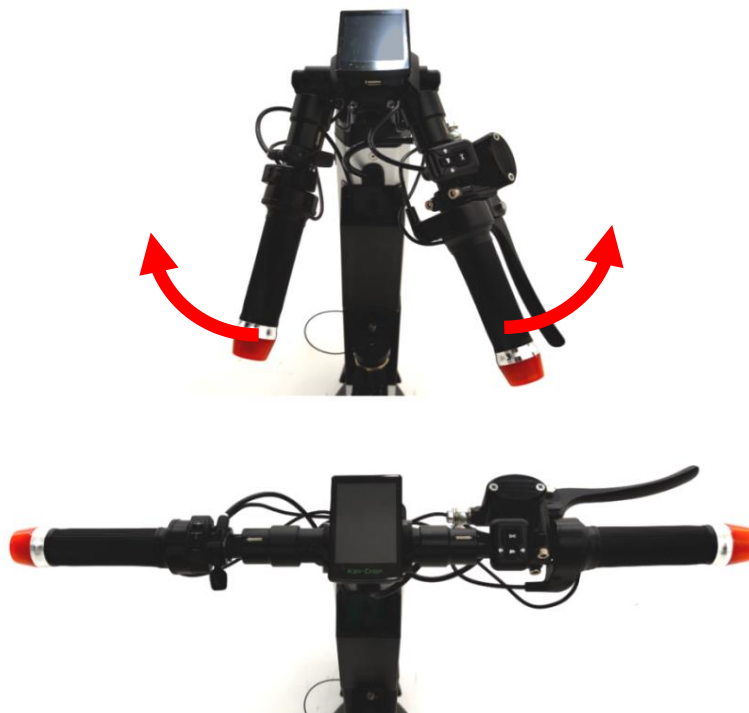

MT03 Manual Instruction

MT03 Connection structure match with manual wheelchair

1. Loosen the **width adjustment bolts** ① and adjust the width of the connection on both sides to make it consistent with the width of the bridge tube of the wheelchair.
2. Adjust the **pipe clamp adjusting bolts** ② to make the pipe clamp suitable for pipe diameters of different thicknesses (the pipe clamp should be clamped on the frame protective case to prevent the frame from being pinched).

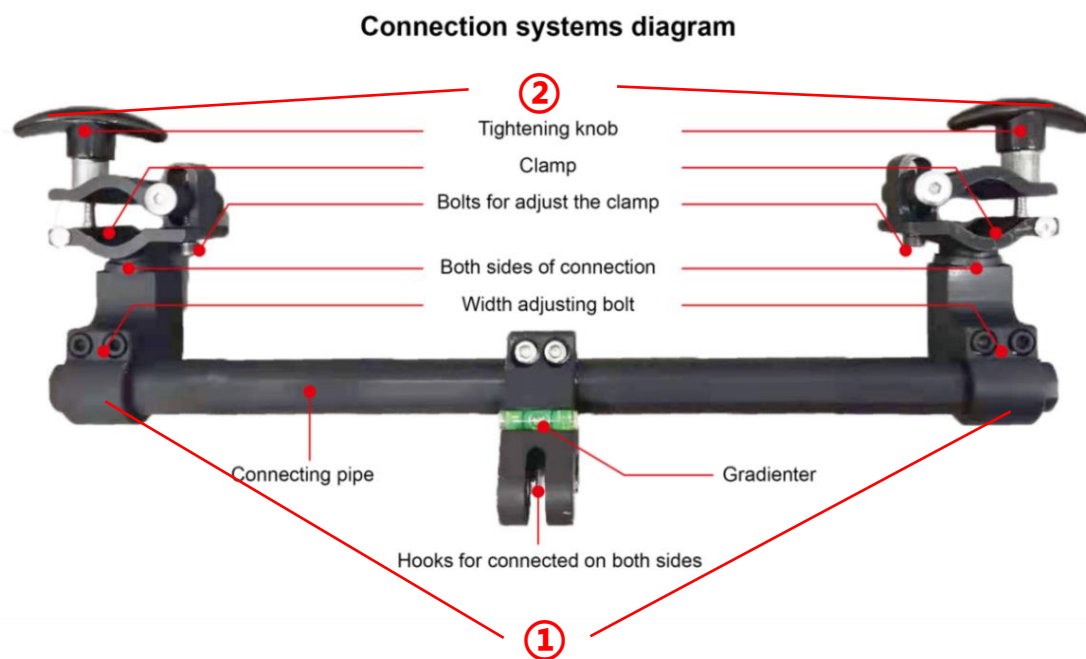

MT03 First time connect with manual wheelchair instruction

- ★ 1. Press the safety handle to keep the body standing steadily.

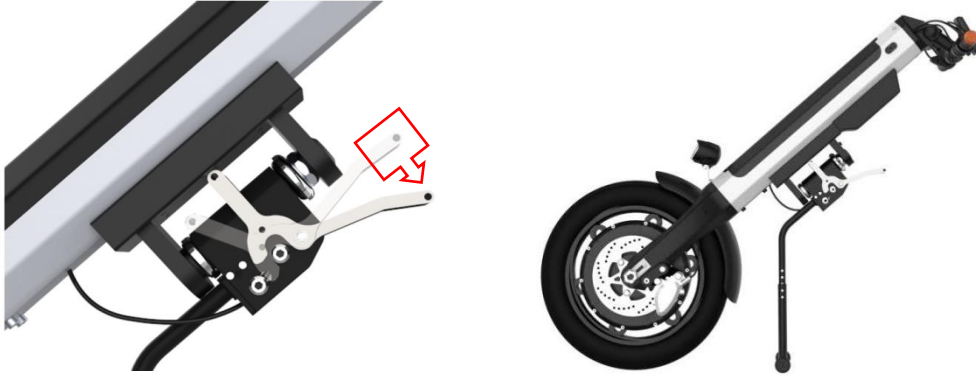

3. Clamp the pipe clamp to a suitable frame of the wheelchair (Note: After the pipe clamps on both sides are clamped, the bubble of Gradienter should be in the middle),align the connection hook with the safety lock,then hook the up connection hook into the safety lock.



4. .Push the handlebar forward and upwards, when you hear a "click", the handbike is adjusted in place. after that, lift up the safety handle ,turn on the power switch and you can ride

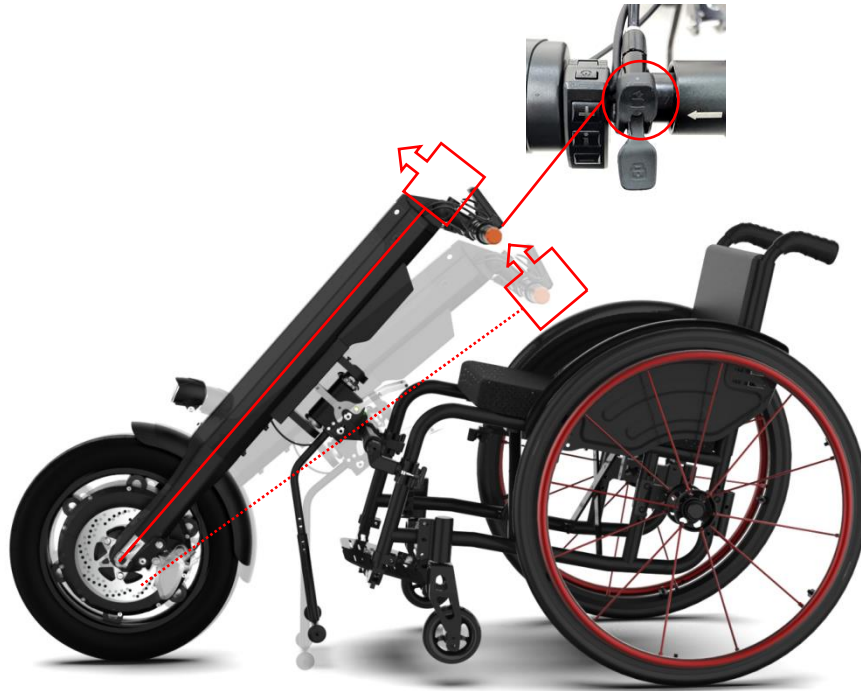

MT03 Disconnecting with wheelchair instruction

- ★ 1. First press the safety handle to keep the body standing steadily, then press the connector switch, at the same time push the handlebar forward and upwards, finally lower the handlebar so that the front wheel and foot support of the wheelchair touch the ground;

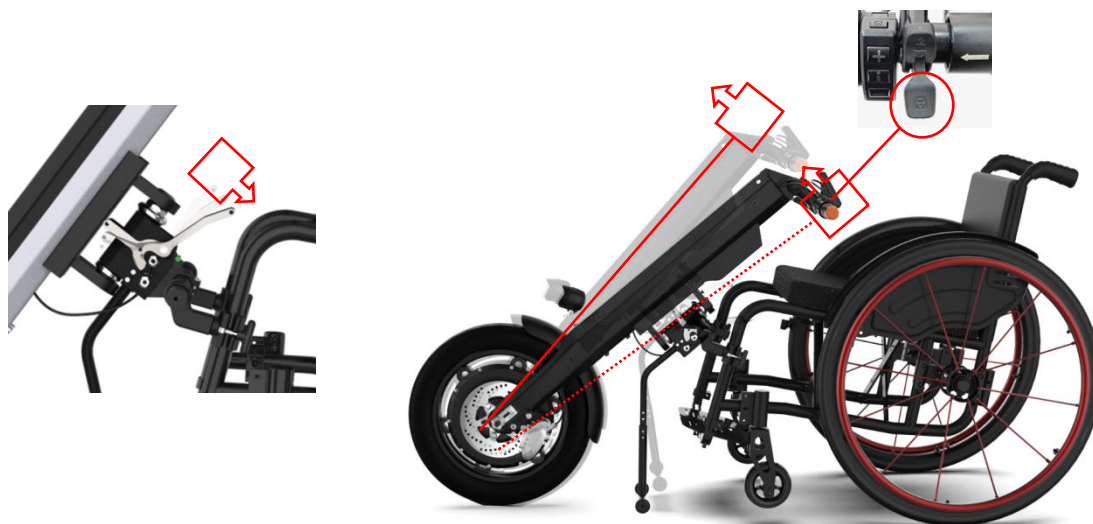

2. Loosen the both side knobs to separate the front of the handbike from the wheelchair;



MT04 Manual Instruction

MT04 Connection structure diagram

1. As shown in the figure, the frame pipe clamp can be installed in three positions below the wheelchair (different installation positions are selected according to different wheelchairs).

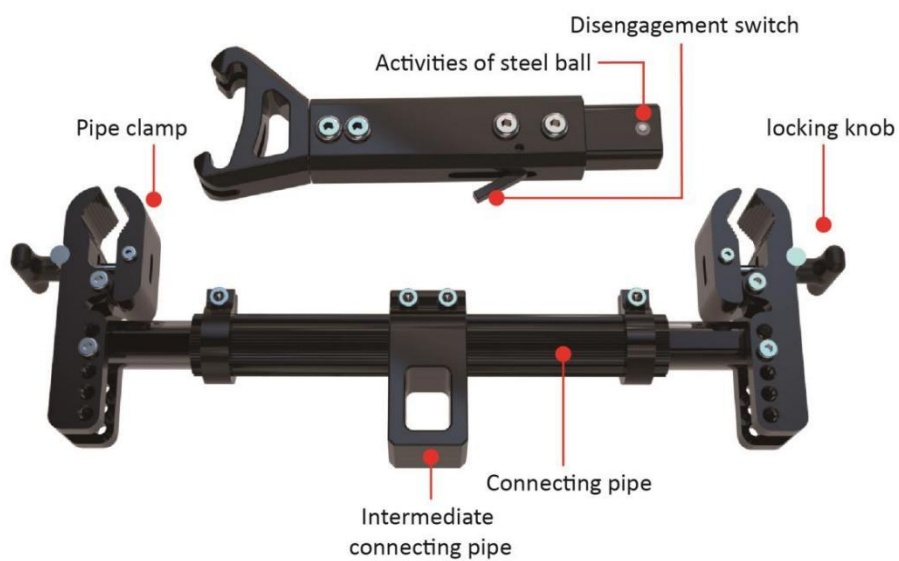

MT04 Clamp installation position



Upper part of wheelchair



Front of wheelchair



Lower part of wheelchair

MT04 First time connecting with wheelchair instruction

1. Loosen the quick-release-pin of the connection pipe first, adjust the overall width, and install the frame tube clamp on the wheelchair. (The intermediate connecting pipes on both sides are about 40cm away from the ground, and the small hole in the middle connecting piece is at the rear).

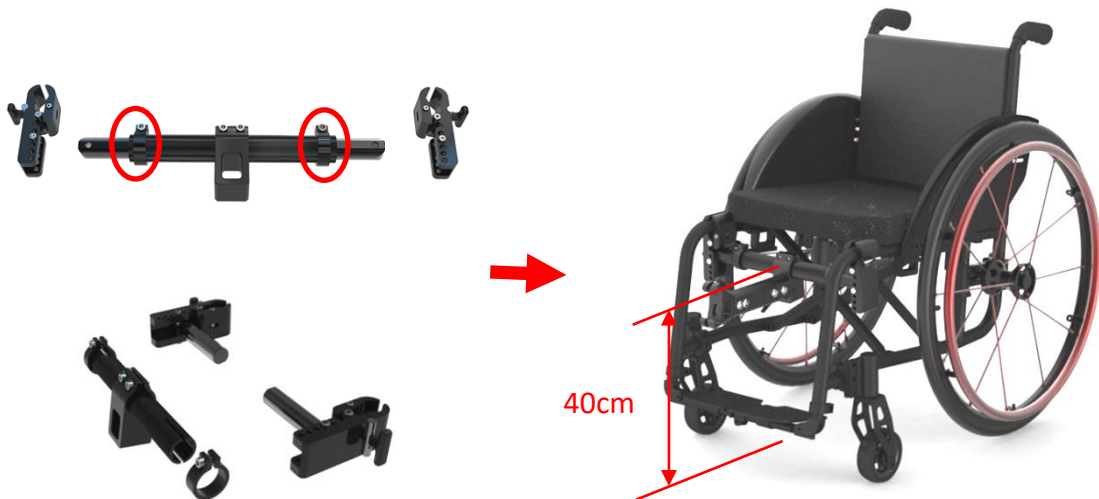

2. Loosen the bolts of the middle connecting piece and adjust the installation hole of the middle connecting piece to be parallel to the ground.

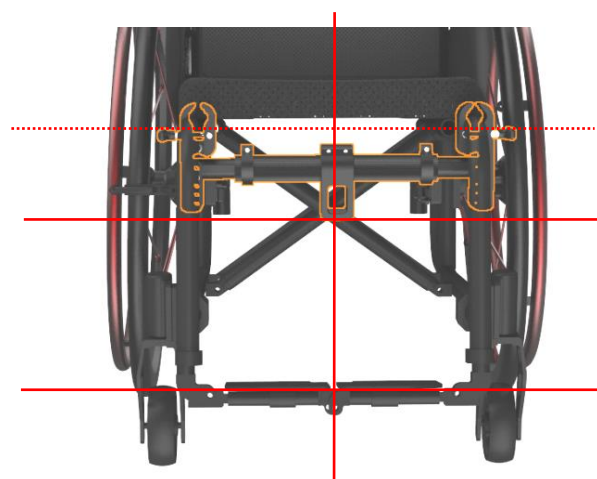

Center

3. Press the release switch of the middle connecting rod, and install the middle connecting rod to the middle connecting piece.



4. Install the frame tube clamp on the wheelchair. (the intermediate connecting pipes on both sides are about 40cm away from the ground, and the small hole in the middle connecting piece is at the rear).



MT04 Disconnecting with wheelchair instruction

- ★ 1. First press the safety handle to keep the body standing steadily, then press the connector switch, at the same time push the handlebar forward and upwards, finally lower the handlebar so that the front wheel and foot support of the wheelchair touch the ground;



2. Push the front of the car forward while gently pressing the handlebar down to complete the separation of the front of the car from the wheelchair.

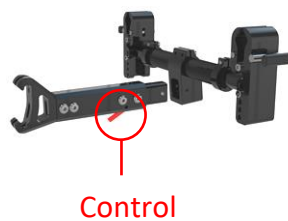

Battery Instructions

Battery related instructions







Note:

Before recharging the handbike, Plug in the battery first, and then Plug in electric power.

After the end of charging, shut off the electric power first, and then unplug the line of battery.

Battery Usage

-  The positive and negative poles of the battery cannot be connected with conductive objects such as metal, which may cause a short circuit or electric shock.
-  Do not approach flammable materials.
-  Do not approach or expose to heat sources, such as open flames or sparks.
- Do not transport the battery with flammable or combustible materials.
-  There are corrosive chemicals in the battery box. It is strictly forbidden to disassemble the battery without permission.
-  It is strictly forbidden to short-circuit the battery or throw the battery into the fire to avoid an explosion accident.

Notes for charging

Warning

1. Do not try to use pliers or cable wires to directly connect the battery terminals to charge the battery.
- ★ 2. Do not use the Handbike when charging the battery.
Do not use non-standard power sources (such as generators or inverters), even if their voltage and frequency appears to meet the requirements.
- ★ 3. Prevent the power cord from being stepped on, pinched and severely bent, especially at the port. Prevent the power cord from being yanked and knotted.
4. Keep children and pets away from the power cord, and do not let them chew or chew the power cord. When unplugging the power cord, hold the plug and pull it out.
5. If the circuit breaker (circuit fuse) trips several times during charging, please unplug the charger immediately and contact the dealer or professional technicians.

The battery warranty and performance indicators mentioned in this guide are all for lithium-ion batteries.

Note

1. After the initial use of the new battery, the first time it is charged, it must be fully charged (about 24 hours) to ensure that the battery is fully activated.
2. Before the initial use, if recharge all the time, which will reduce the service life of the battery (the battery should be fully used up for the first time, and then start charging, so that the battery can be fully activated.)
3. Check whether the power supply is sufficient before use, and charge in time when the power is insufficient. When the power is exhausted, charging takes 6-8 hours, until the red light on the charger turns green.
4. The recommended range for each battery charging time is about 6 to 8 hours.
- ★ 5. Charge the battery frequently. As long as the trailer is in use, charge the battery after use until it is fully charged. If the trailer is not used for a long time, please recharge the trailer once every 2 months, charging about 80% of the electricity each

time. If the battery is out of power for a long time, the battery will be damaged, the battery will be unusable, and the Handbike will be damaged seriously.

★ 6. If you use batteries with incorrect specifications, voltage and capacity, your Handbike may be damaged, and the Handbike may not achieve the best performance and effect.

7. The cycle times of the battery are 700 weeks, and the service life is 2-5 years. If the battery is damaged, you can contact our company's after-sales service for replacement.

Battery Installation and removal



Please make sure that the power to the Handbike is turned off before performing this operation.

Remove the battery:

1. Pull up the battery to prevent tripping
2. Turn the key, after seeing the battery pop up, let go to return the key
3. Rotate the battery upward and remove the battery

① Put the battery into the battery box ② Press the battery down ③ Turn off battery anti trip



Install the battery:

1. Put the battery in the battery box
2. Gently press down on the battery, after hearing a "click" sound, the battery is installed in place.
3. Slide the battery anti-trip down to lock the battery.

① Turn on battery anti trip

② Rotating power key

③ Take out battery



Battery Charging

It can be charged with standard AC power (AC 110-220 V, 50-60 Hz). Make sure to turn off the power of the handbike before charging.

Insert the charging plug of the charger into the charging port on the lower front of the control panel and insert the battery charging port to charge (the battery can be removed and charged separately, or it can be directly charged on the handbike).

1. Insert the charger plug into the network power supply. When the red indicator light is on, it means it is charging.
2. The red indicator light is on to indicate that it is charging. When the charger indicator turns from red to green, keep charging for another 30 minutes to ensure that the battery is fully charged.
3. After charging is completed, unplug the network power socket first, and then unplug the charging plug.
4. Please charge at 0-45°C in an environment suitable for charging.

Over Discharge Protection Device

When the battery of the handbike is exhausted, the over-discharge protection device will protect the battery from over-discharge. The user should note that the maximum speed will decrease when the over-discharge protection device is activated. In this case, please charge the battery as soon as possible.

Over current protect device

This handbike also equipped with an over current protect device. If the current supplied to the motor becomes excessive, the electronic fuse will turn off the current. When driving a handbike in trouble, over current protection will be activated, and the driving wheels of the wheelchair will be blocked in motion. This process is the fuse cut off the current to prevent the motor from overheating and damage.

Warranty Coverage

Warranty items	Free warranty period	Remarks
Main frame	3 years	Failure due to improper use, man-made sabotage or unauthorized modification, no warranty. Or maintenance fee will be charged.
Motor	1 year	Excessive load causes the motor to be overloaded or is damaged by disassembling the motor privately, No warranty
Battery	1 year	If the battery is not charged in the correct way, or if the battery is disassembled without authorization, it will not be guaranteed, and the company is not responsible for the accident.
Controller	1 year	The controller malfunctions due to improper use, man-made destruction or unauthorized modification, no warranty. Or maintenance fee will be charged.

Not covered by warranty

1. We do not guarantee:

- a) Tires, disc brakes, decorative parts, etc. are damaged after use.
- b) Damage caused by negligence in operation, accidents, misuse, improper installation and repair.
- c) Problems caused by product conversion without the written consent of Jiangsu Mijo Technology Co., Ltd.
- d) Damage caused by load exceeding the maximum load-bearing.

2. If the serial number on the handbike is not the original serial number, if be modified, or is inconsistent with the serial number on the warranty card, or the serial number on the warranty card be altered, the warranty will not be granted.

3. This warranty card is non-transferable and only for the purchaser of the handbike. As a manufacturer, the company's responsibility is to repair or replace damaged parts.

To the extent permitted by law, this warranty description will replace any other warranty (such as written or oral, express or implied guarantees, including guarantees of merchantability, or suitability for a specific purpose). All are subject to the warranty certificate.

Labels, Packing Logo Design

Symbol	Introductions	Symbol	Introductions
	Batch Code		Keep dry
	Warnings and Precautions		Non-sterile
	Medical device		Manufacture Date
	Manufacturer Name Address		Name and Address of European Union Representative
	Symbol for “Consult instructions for use”		Don't roll
	CE Symbol		Symbol for “Keep out rain and snow”
	Up side		Model Number
	Importer		Distributor
	Country of Manufacture		Unique Device Identification

Accessories

Name	Quantity	Remarks
Charger	1	/
User manual	1	/
Hexagon wrench	2	/
Key	2	/

Manufacturer Information



Company: Jiangsu Mijo Technology Co., LTD

Address: Room 309, Block A, Merchants E Town, Baohua Town, Jurong City

Tel:86-0511-80279699

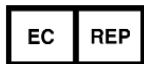

SUNGO Europe B.V.

Olympisch Stadion 24, 1076DE Amsterdam, Netherlands